

372 Series

TR5 Fuse, Time Lag

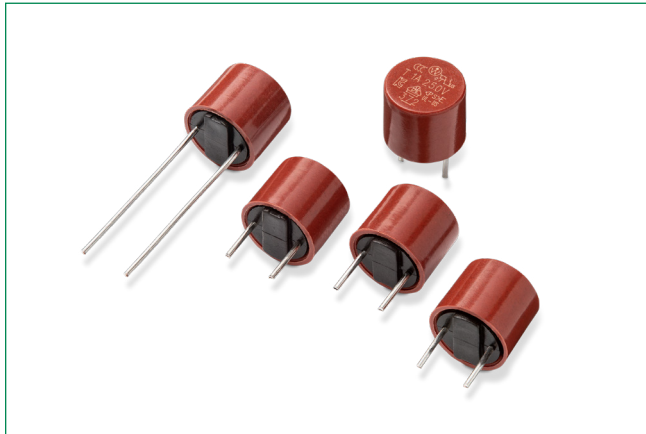

Description

The 372 Series are TR5® Fuses, Time-Lag type, 250V rated fuses, that are designed in accordance to IEC 60127-3.

Features and Benefits

- Halogen free, Lead-free and RoHS compliant
- Reduced PCB space requirements
- Direct solderable or plug-in versions
- Internationally approved
- Low internal resistance
- Shock safe casing
- Vibration resistant
- Available from 0.040A to 6.3A
- Recognized to UL/CSA/NMX 248-1 and UL/CSA/NMX 248-14
- Conforms to EN/J/K 60127-1 and EN/J/K 60127-3
- Conforms to GB/T 9364.1 and GB/T 9364.3
- CE Mark indicates compliance with Low-Voltage and RoHS Directives.

Additional Information



Resources



Accessories



Samples

Applications

- Battery Chargers
- Consumer electronics
- Power supplies
- Industrial Controllers

Agency Approvals

Agency	Agency File/Certificate Number	Ampere Range
UK CA	NA	40mA - 6.3A
D'E	97187 116448	0.050A - 4A 5A - 6.3A
PS E	NBK291021-JP1021	1A - 5A
C UL US	E67006	0.040A - 6.3A
CE	N/A	0.125A - 20A
UK CA	SU05024-7010	0.050 - 0.100A
	SU05024-7011	0.125 - 0.800A
	SU05024-7006	1A - 2.5A
	SU05024-7007	3.15A
	SU05024-7008	4A
	SU05024-7009	5A
CCC	2020970207000055	0.040A - 6.3A

Electrical Characteristics

% of Ampere Rating	Opening Time
150%	1 Hour, Min.
210%	2 Minutes, Max.
275%	400 ms, Min. ; 10 Sec., Max.
400%	150 ms, Min. ; 3 Sec., Max.
1000%	20 ms, Min. ; 150 ms, Max.

372 Series

TR5 Fuse, Time Lag

Electrical Characteristics

Amp Code	Rated Current	Voltage Rating	Breaking Capacity	Nominal Cold Resistance (Ohms)	Voltage Drop $1.0 \times I_N$ max. (mV)	Power Dissipation $1.5 \times I_N$ max. (mW)	Melting Integral $10 \times I_N$ min. (A ² s)	Agency Approvals						
0040	40mA	250V	35A@250VAC	10.1650	900	90	0.0090	-	X	-	X	-	X	X
0050	50mA	250V		6.4950	500	70	0.0108	X	X	-	X	X	X	X
0063	63mA	250V		3.8000	400	80	0.0278	X	X	-	X	X	X	X
0080	80mA	250V		2.8750	370	100	0.0384	X	X	-	X	X	X	X
0100	100mA	250V		1.7030	300	110	0.0800	X	X	-	X	X	X	X
0125	125mA	250V		1.3500	260	120	0.1094	X	X	-	X	X	X	X
0160	160mA	250V		0.7780	200	130	0.1792	X	X	-	X	X	X	X
0200	200mA	250V		0.5750	170	140	0.3120	X	X	-	X	X	X	X
0250	250mA	250V		0.4000	150	150	0.4938	X	X	-	X	X	X	X
0315	315mA	250V		0.2760	140	160	0.3969	X	X	-	X	X	X	X
0400	400mA	250V		0.2050	130	170	1.4080	X	X	-	X	X	X	X
0500	500mA	250V		0.1550	125	180	2.0000	X	X	-	X	X	X	X
0630	630mA	250V		0.1150	120	200	3.0958	X	X	-	X	X	X	X
0800	800mA	250V	0.1000	110	220	5.7600	X	X	-	X	X	X	X	
1100	1.00A	250V	0.0790	110	360	7.5000	X	X	X	X	X	X	X	
1125	1.25A	250V	0.0550	95	450	13.7500	X	X	X	X	X	X	X	
1160	1.60A	250V	0.0420	95	450	19.9680	X	X	X	X	X	X	X	
1200	2.00A	250V	0.0300	85	600	30.0000	X	X	X	X	X	X	X	
1250	2.50A	250V	0.0220	80	700	35.0000	X	X	X	X	X	X	X	
1315	3.15A	250V	0.0173	80	1100	77.3955	X	X	X	X	X	X	X	
1400	4.00A	250V	40A / 250 VAC	0.0129	75	1200	126.4000	X	X	X	X	X	X	
1500	5.00A	250V	50A / 250 VAC	0.0094	80	1300	115.0000	X	X	X	X	X	X	
1630	6.30A*	250V		0.0070	58	1250	138.9150	X	X	-	X	X	X	

1 Per UL, approved breaking capacity is 50 A at 250 V.

* Conducting path min. 0.2 mm²

Notes:

1) 1.00 means the number one with two decimal places. 1,000 means the number one thousand.

2) Resistance is measured at 10% of rated current, 25°C.

Temperature Re-rating Curve

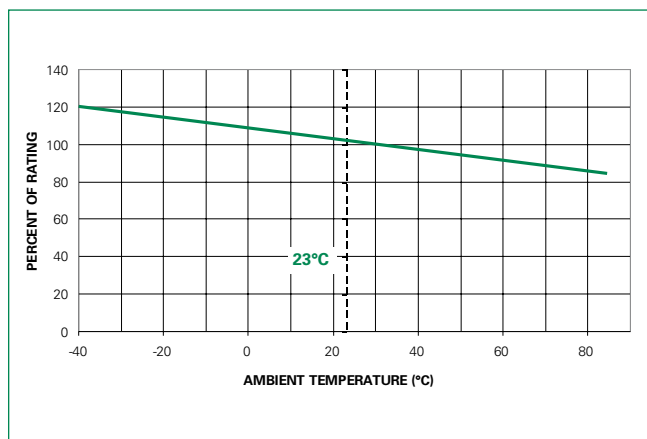

Note

1. Derating depicted in this curve is in addition to the standard derating of 25% for continuous operation.

Average Time Current Curves

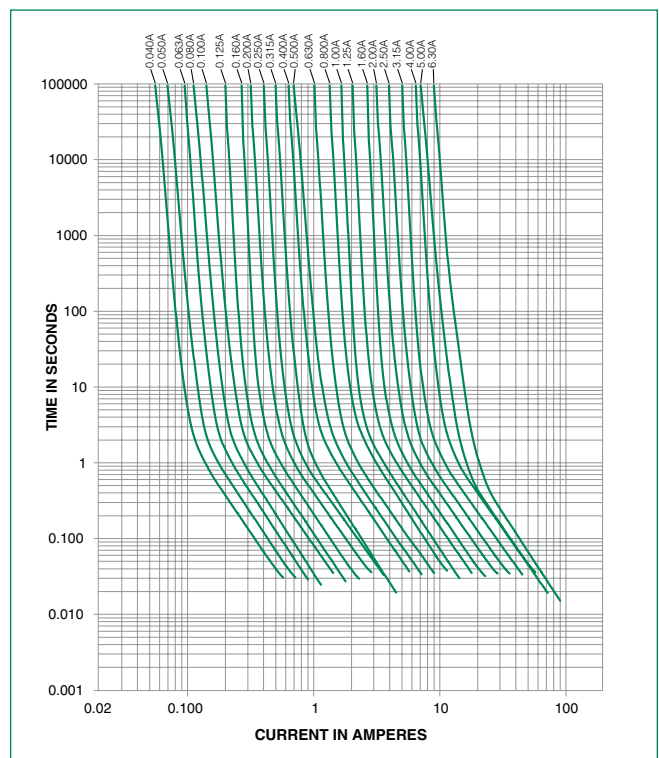

372 Series

TR5 Fuse, Time Lag

Soldering Parameters - Wave Soldering

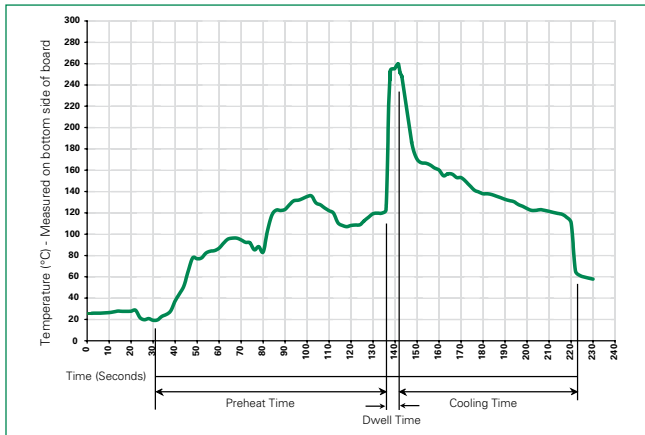

Recommended Process Parameters:

Wave Parameter	Lead-Free Recommendation
Preheat: (Depends on Flux Activation Temperature)	(Typical Industry Recommendation)
Temperature Minimum:	100°C
Temperature Maximum:	150°C
Preheat Time:	60-180 seconds
Solder Pot Temperature:	260°C Maximum
Solder Dwell Time:	2-5 seconds

Recommended Hand-Solder Parameters:

Solder Iron Temperature: 350°C +/- 5°C
Heating Time: 5 seconds max.

Note: These devices are not recommended for IR or Convection Reflow process.

Product Characteristics

Materials	Base/Cap: Brown Thermoplastic Polyamide PA 6.6, UL 94 V-0 Round Pins: Copper, Tin-plated
Lead Pull Strength	10 N (IEC 60068-2-21)
Solderability	260°C, ≤ 3s. (Wave) 350°C, ≤ 1s. (Soldering Iron)
Soldering Heat Resistance	260°C, 10s. (IEC 60068-2-20) 350°C, 3s. (Soldering Iron)
Operating Temperature	-40°C to +85°C (Consider re-rating)
Climatic Category	-40°C/+85°C/21 days (IEC 60068-1,-2-1,-2-2,-2-78) +10°C to +60°C
Stock Conditions	RH ≤ 75% yearly average, without dew, maximum value for 30 days-95% 24 cycles at 15 min. each (IEC 60068-2-6)
Vibration Resistance	10 - 60 Hz at 0.75 mm amplitude 60 - 2000 Hz at 10G's acceleration

Dimensions (mm)

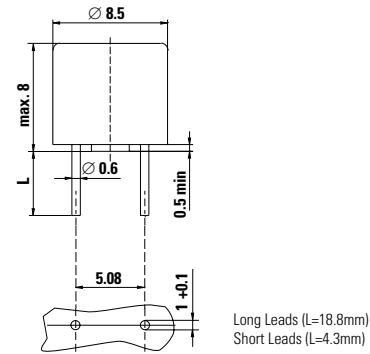

Packaging

Packaging Option	Packaging Specification	Quantity	Quantity & Packaging Code	Taping Width
372 Series				
Tape & Ammopack	N/A	1,000	0001	N/A
Short Leads	N/A	1,000	0411	N/A
Short Leads	N/A	200	0431	N/A
3.3mm Leads	N/A	1,000	0511	N/A

Part Numbering System

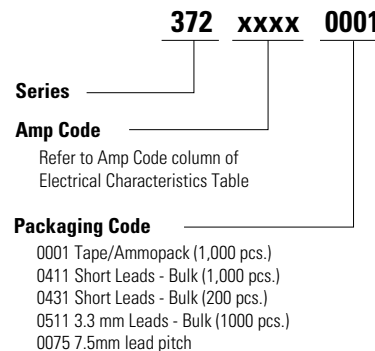

Disclaimer Notice - Information furnished is believed to be accurate and reliable. However, users should independently evaluate the suitability of and test each product selected for their own applications. Littelfuse products are not designed for, and may not be used in, all applications. Read complete Disclaimer Notice at: www.littelfuse.com/disclaimer-electronics.